

**SD/MMC INTERFACE (1.8V - NO TRANSLATION)**

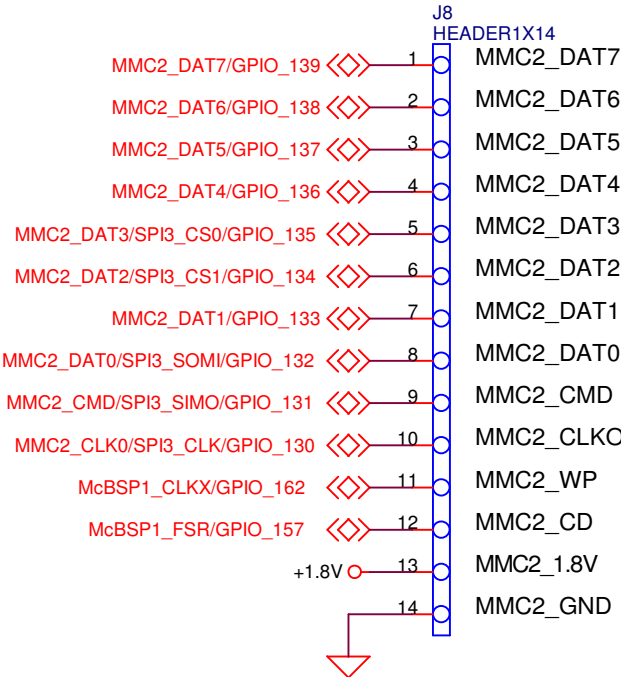

**Expansion Connector**

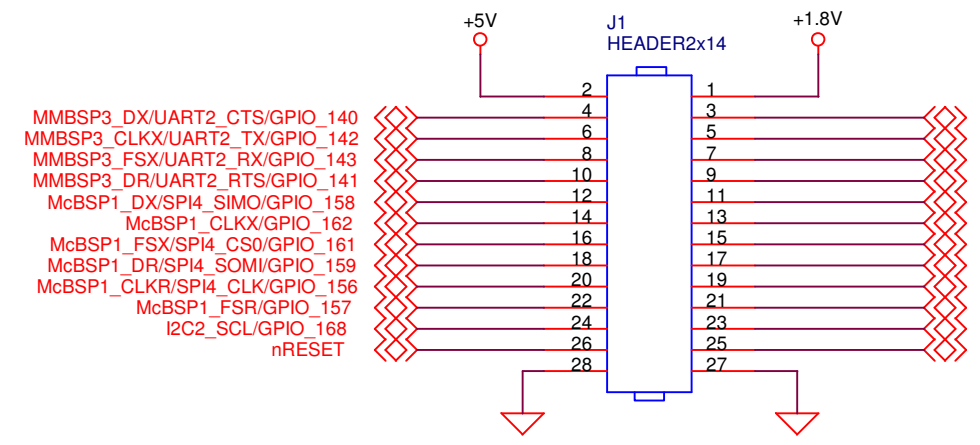

MMBSP3\_DX/UART2\_GTS/GPIO\_140  
 MMBSP3\_CLKX/UART2\_TX/GPIO\_142  
 MMBSP3\_FSX/UART2\_RX/GPIO\_143  
 MMBSP3\_DR/UART2\_RTS/GPIO\_141  
 McBSP1\_DX/SPI4\_SIMO/GPIO\_158  
 McBSP1\_CLKX/GPIO\_162  
 McBSP1\_FSX/SPI4\_CS0/GPIO\_161  
 McBSP1\_DR/SPI4\_SOMI/GPIO\_159  
 McBSP1\_CLKR/SPI4\_CLK/GPIO\_156  
 McBSP1\_FSR/GPIO\_157  
 I2C2\_SCL/GPIO\_168  
 nRESET

MMC2\_DAT7/GPIO\_139  
 MMC2\_DAT6/GPIO\_138  
 MMC2\_DAT5/GPIO\_137  
 MMC2\_DAT4/GPIO\_136  
 MMC2\_DAT3/SPI3\_CS0/GPIO\_135  
 MMC2\_DAT2/SPI3\_CS1/GPIO\_134  
 MMC2\_DAT1/GPIO\_133  
 MMC2\_CMD/SPI3\_SIMO/GPIO\_131  
 MMC2\_CLK0/SPI3\_CLK/GPIO\_130  
 I2C2\_SDA/GPIO\_183  
 REGEN

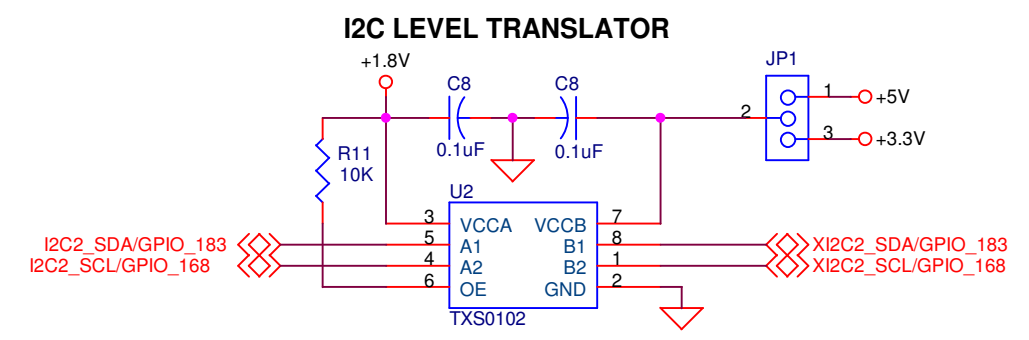
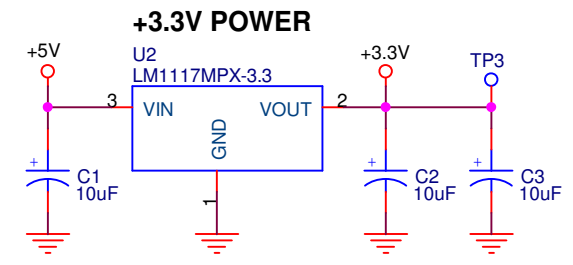
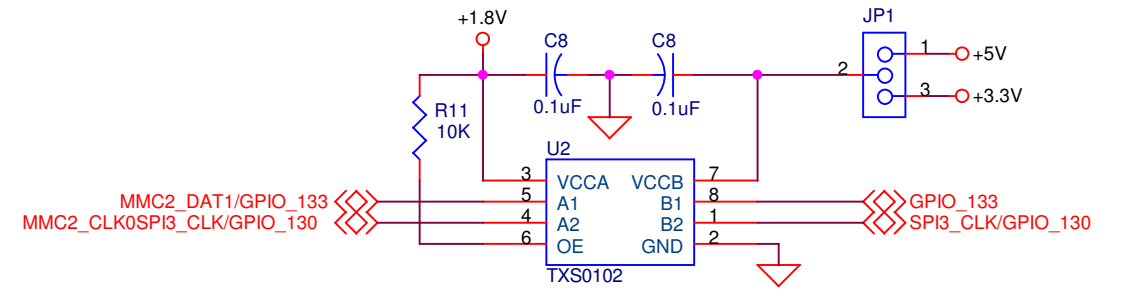
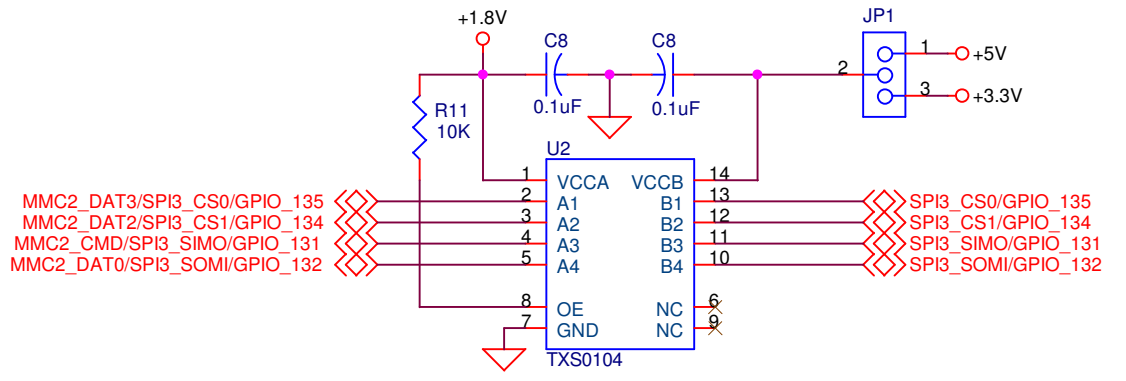
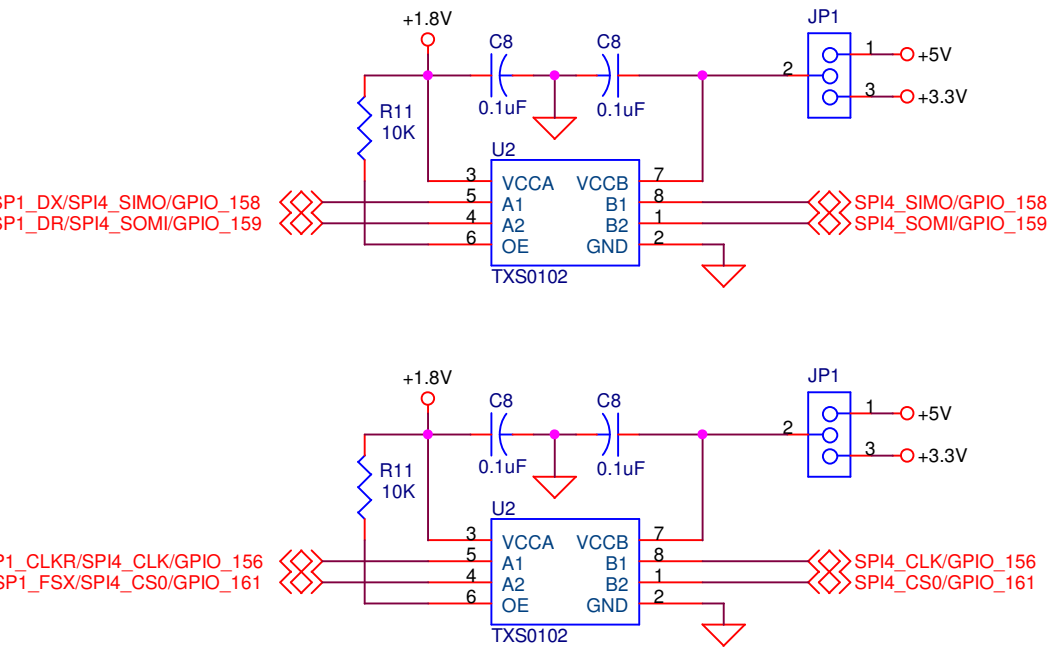

<a href="http://www.TinCanTools.com">www.TinCanTools.com</a>		
<b>BeagleBoard Expansion Board</b>		
Size B	Document Number	Rev
	<b>BB_Expansion_Board</b>	<b>01</b>
Date:	Monday, October 13, 2008	Sheet 1 of 1

