

Maintainer's Diary: We have a scaling problem

Wolfram Sang

Consultant



Statistics: # of patches

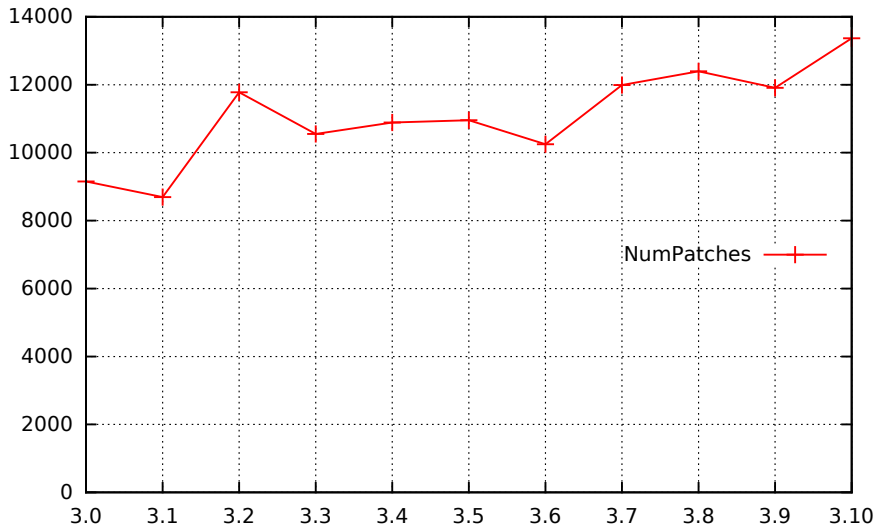

Statistics: # of people

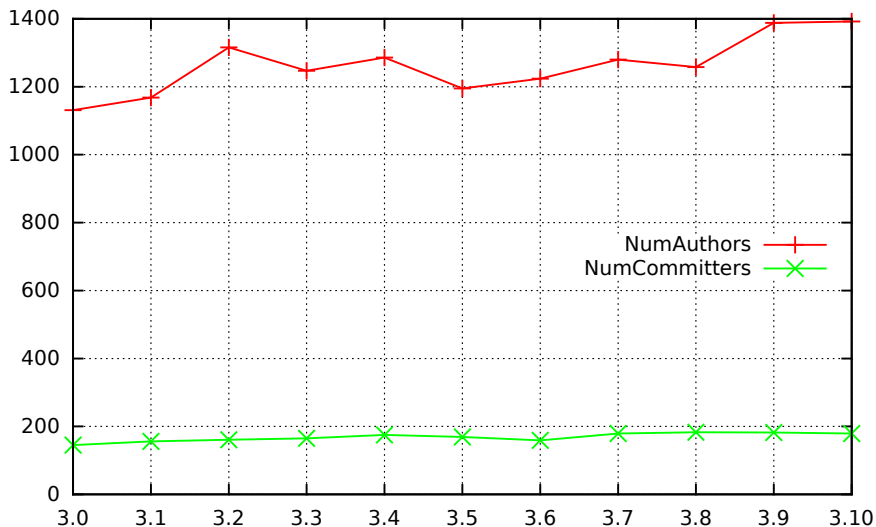

Statistics: increase of people

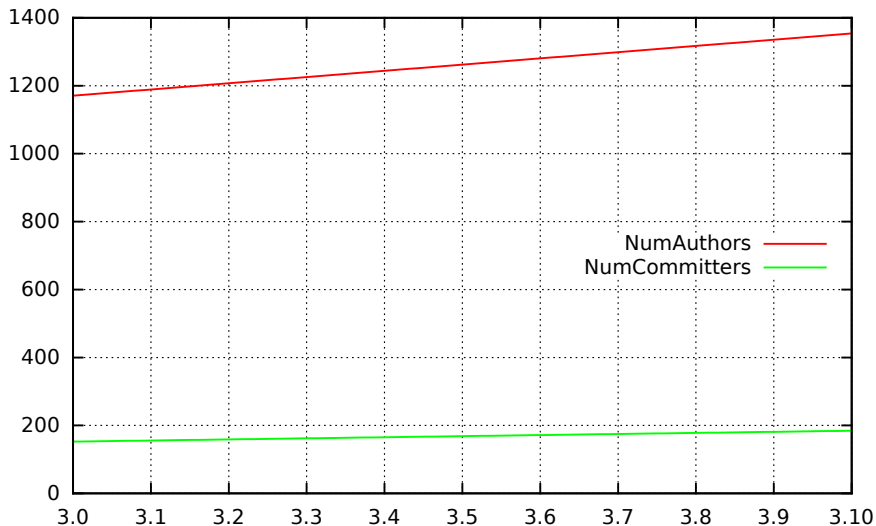

- Stats only based on accepted patches

There are also superseded, rejected patches, teaching new authors...

- Situation at v3.0 was already far from ideal

Can we offload tasks?

What is a maintainer? Trond Myklebust said it nicely¹:

"Currently, the Linux maintainer appears to be responsible for filling all of the traditional roles of

- software architect
- software developer
- patch reviewer
- patch committer
- and software maintainer."

¹link here

Yes, this is a rare bunch!²

²but they usually have fun doing that :)

Statistics: # of people (with supporters)

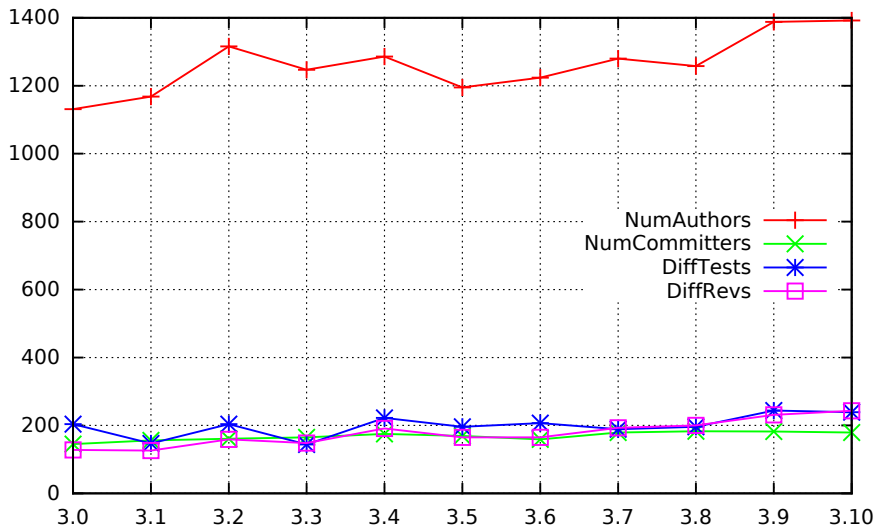

Statistics: increase of people (with supporters)

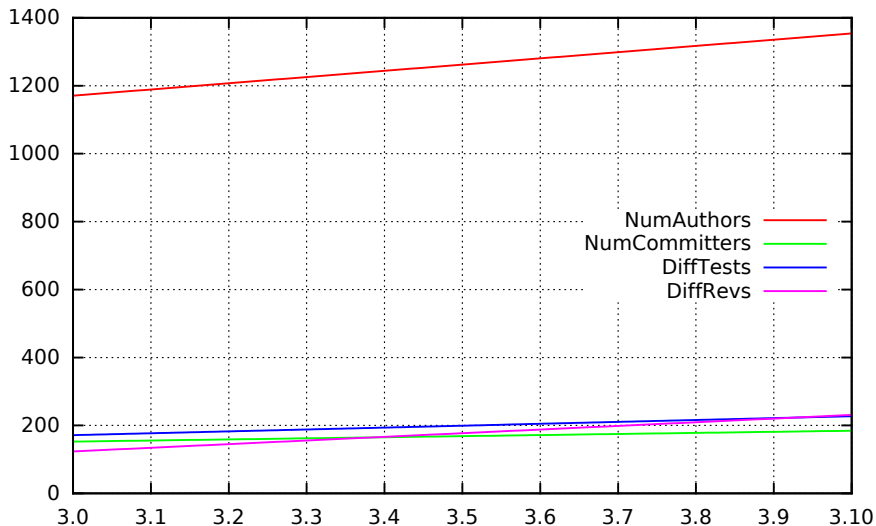

A typical (simple) SoC

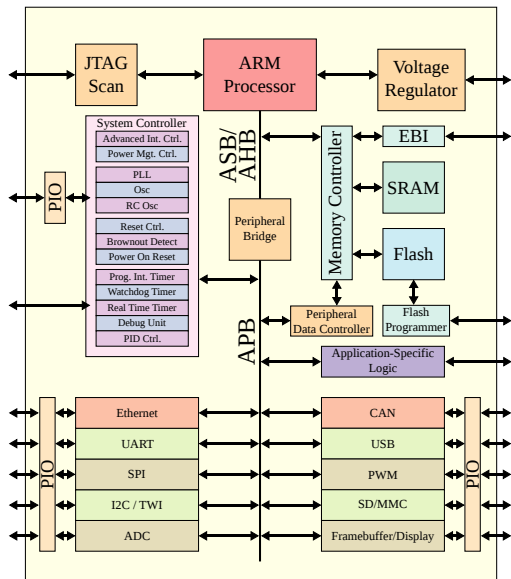

Statistics: Subsystem Latency

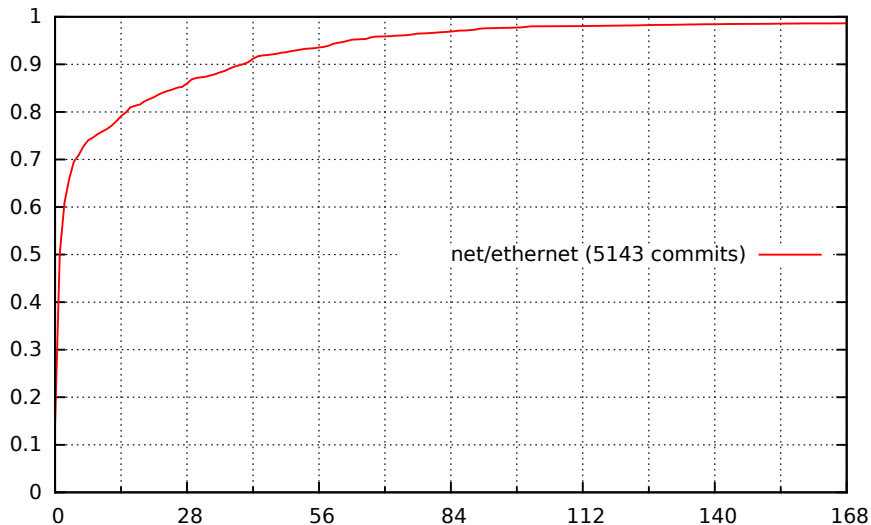

Statistics: Subsystem Latency

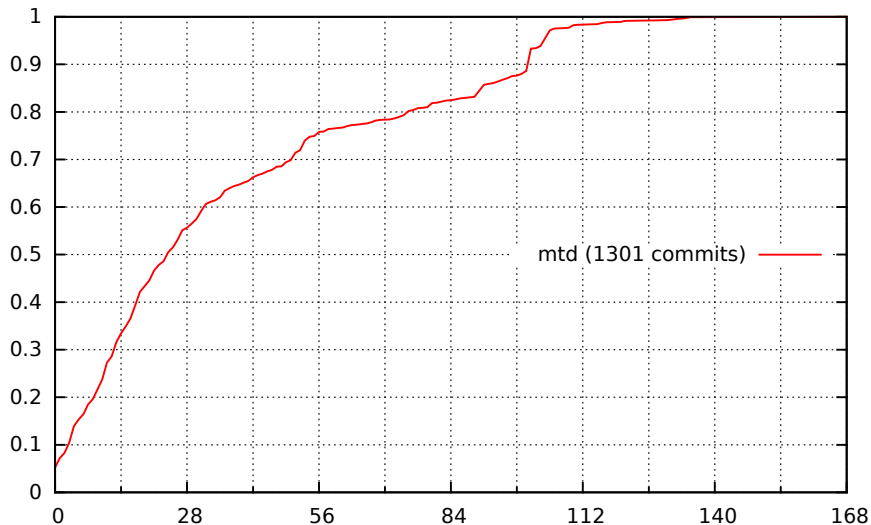

Statistics: Subsystem Latency

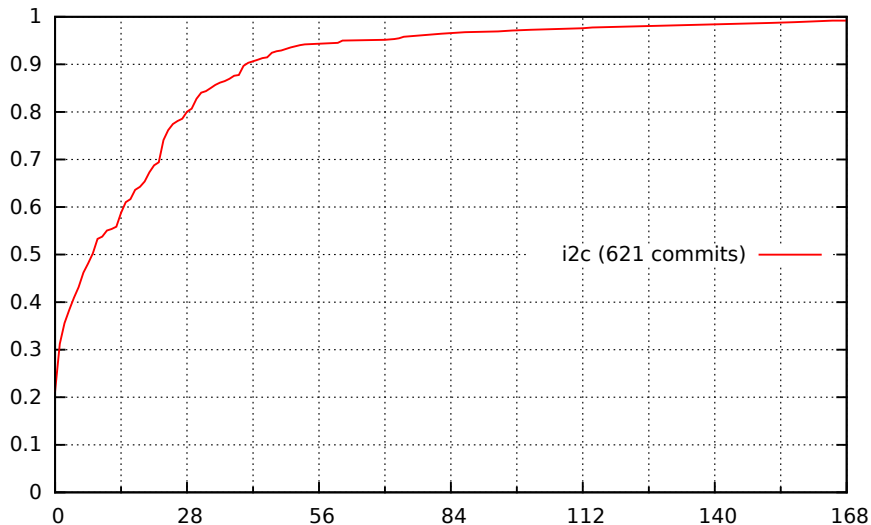

Statistics: Subsystem Latency

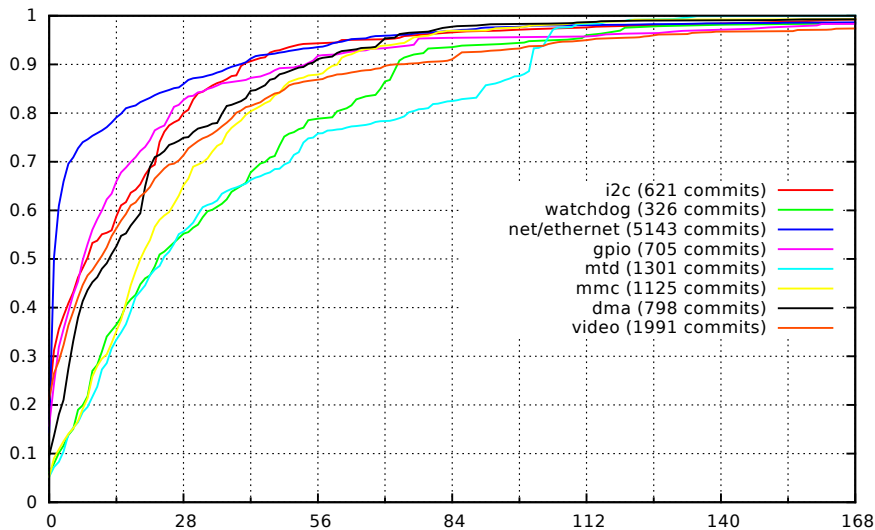

Statistics: Subsystem Latency

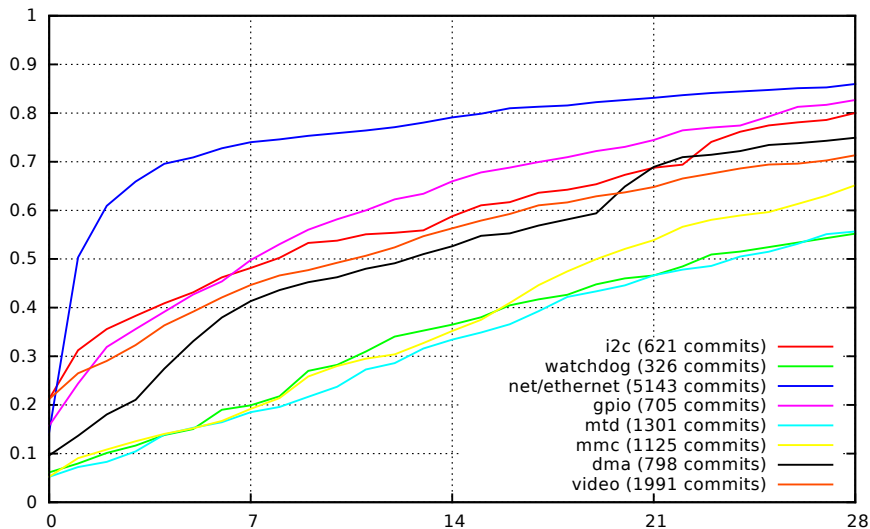

- Again: Stats only based on accepted patches
- There are also totally valid patches which got lost
Couldn't find a way to measure that, though
- Weather forecast: Situation will get worse
Expect either increased latency or questionable patches coming in

What you can do: Users³

Give feedback

- give comments about patches
- give tags (Tested-by:)

resend overlooked patches

- only if you still use and need them
- check if there are open issues
- resend

³as in "users of patches"

What you can do: Developers

Always give your best shot

- missing experience is no problem
- sloppiness *is* a problem
- be honest, give reasons for suboptimal solutions

take part in Q&A

- review
- review your own patches
- discuss
- clean up, consolidate
- if you are interested, become a maintainer

What you can do: Maintainers

Work harder...*not!*

- we don't need burnout
- be aware of the fast-forward button

have your tools ready

- yeah, workflow is highly subjective...
- ...still check with other maintainers what is out there
- My top three recommendations
 - keyboard shortcuts
 - git hooks
 - patchwork
 - did you know it collects tags for you?

automize tasks

- really pay attention to boring, repetitive tasks
- have I mentioned proper tools?

What you can do: Organizations

allow developers to take part in Q&A

- some really want to if allowed
- those will improve their skills a lot

educate internally

- OK to ask maintainer for subsystem specific help
- not OK to let maintainers teach basic stuff
if I know you have people inhouse which can do the same

What you can do: Organizations

be aware that things might take time

- we are trying to be fast, yet there is overload

see maintaining as a job on its own

- worth being paid for, directly or indirectly
- independent maintainers are best, see Linus or Greg
although with enough credit, it will work, too
- probably *the* item to improve the situation

Thank you for your attention!

Let's go for it!

Questions?

- Right here, right now...
- Later at the conference
- wsa@the-dreams.de